

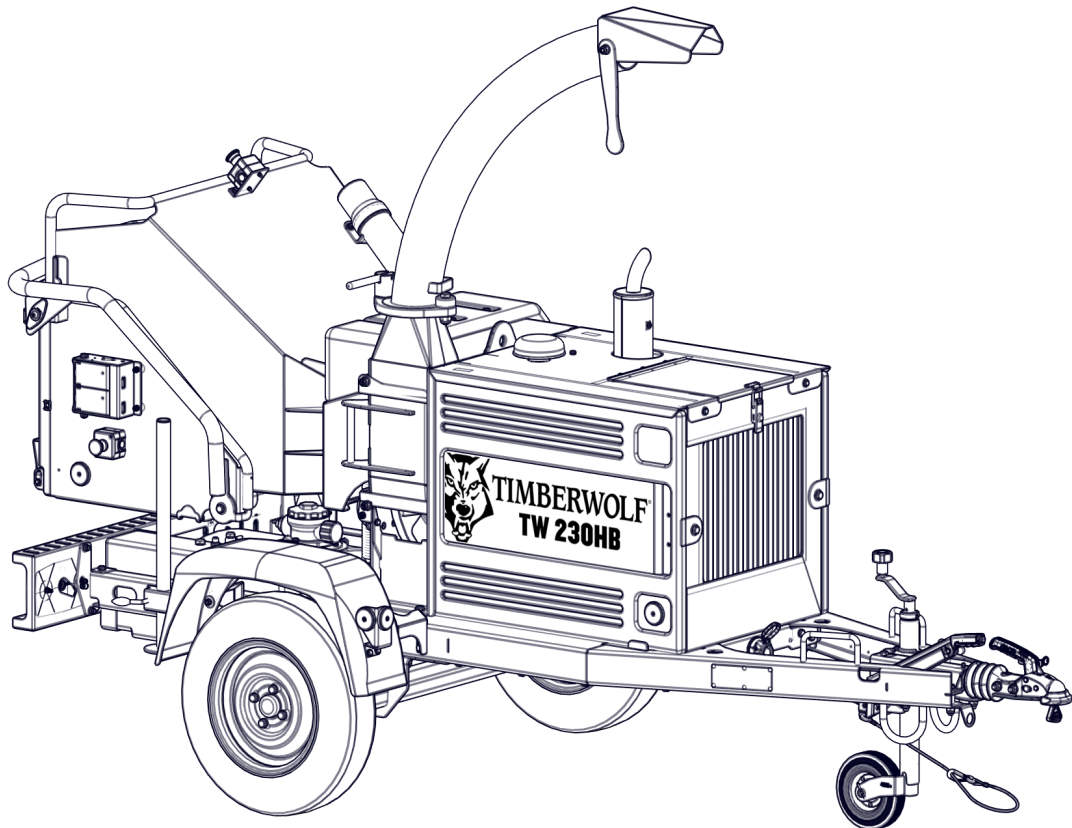

TIMBERWOLF®

Lead the Pack



TW 230HB (Diesel) Wood Chipper

INSTRUCTION MANUAL

(Original Instructions)

Published on: 20/01/2022

Document ID: C190-0302 - Revision 3.0

Contact address

Timberwolf Ltd
Entec House
Tomo Industrial Estate
Stowmarket
Suffolk
IP14 5AY
United Kingdom

Website

English	timberwolf-uk.com
French	timberwolf.fr
German	timberwolf-hacksler.de
Dutch	timberwolf-houtversnipperaar.nl
Australian	timberwolfchippers.com.au

Copyright

Copyright © 2022 Timberwolf All Rights Reserved.

Contains information owned by Timberwolf and/or its affiliates. Do not copy, store, transmit or disclose to any third party without prior written permission from Timberwolf.

Other product and company names may be trademarks or registered trademarks of other companies, and are the property of their owners. They are used only for explanation, without intent to infringe.



Contents

1	Introduction	5
1.1	Thank you for choosing Timberwolf	5
1.2	Important Health and Safety Information	5
1.3	Warning or Caution Symbols	6
1.4	Hazardous Materials	6
1.5	Purpose	6
2	Product Details	7
2.1	Specification	7
2.2	Location of Parts	8
2.2.1	Parts Locator 1	8
2.2.2	Parts Locator 2	9
2.2.3	Parts Locator 3	10
2.3	Tool Box	10
2.4	Safety Decals	11
2.5	Instruction Decals	12
2.6	Model Decals	14
2.7	Identification Plate	15
2.8	Guards	15
3	Safety Notes and Warnings	17
3.1	Safety Notices	17
3.2	Operator's Personal Protective Equipment (PPE)	17
3.3	Basic Woodchipping Safety	18
3.4	Operating Safely - You MUST	19
3.5	Operating Safely - You MUST NOT	19
3.6	Noise Emissions	20
4	Towing and Handling	21
4.1	Safe Transportation	21
4.2	Hitching to the Towing Vehicle	21
4.3	Unhitching from the Towing Vehicle	22



4.4	Stabilising the Chipper	23
5	Operating Instructions	25
5.1	Manual Controls	25
5.2	No Stress Control	26
5.3	Emergency Stopping	26
5.4	Discharge Controls	27
5.5	Engine Controls	27
5.6	Checks Before Starting	28
5.7	Starting the Engine	28
5.8	Controlling the Engine Speed	29
5.9	In-feed and Emergency Stop Safety Tests	29
5.10	Chipping	31
5.11	Working in Dusty Conditions	31
5.12	Stopping the Engine	31
5.13	Blockages	32
5.14	Blade Wear	32
5.15	Check Hydraulic Oil Level	33
5.16	Check Fuel Level and Refuel	33
5.17	Troubleshooting	34
6	Maintenance Instructions	35
6.1	Safe Maintenance	35
6.2	Routine Servicing	36
6.2.1	Daily Servicing	36
6.3	Spares	36
6.4	Engine Servicing	37
6.5	Safe Lifting of the Chipper	37
6.6	Battery Safety Information	38
6.7	Check and Replace Fasteners	40
6.8	Change Blades	41
6.9	Adjust Rotor Drive Belt Tension	43
6.10	V-Belt Tensioning Procedure	44
6.11	Change Hydraulic Oil and Filter	45



6.12	Check Hoses	45
6.13	Grease the Discharge Tube Mounting Flanges	46
6.14	Grease the Roller Box Slides	46
6.15	Grease the Roller Splines and Rotor Bearings	47
7	Electrical System	49
8	Hydraulic System	51
9	Storage	53
9.1	Preparing for Storage	53
9.2	Storage Conditions	53
9.3	3-Monthly Storage Checks	53
9.4	6-Monthly Storage Checks	53
9.5	12-Monthly Storage Checks	54
9.6	Recommissioning after Storage	54
10	Dismantling and Disposal	55
11	Declaration of Conformity	57
12	Notes	59



THIS PAGE INTENTIONALLY LEFT BLANK



1 Introduction

1.1 Thank you for choosing Timberwolf

Timberwolf wood chippers are designed to give safe and dependable service if operated in accordance with the instructions.

This manual should be considered an important part of the machine and should remain with it if the machine is resold.

This manual covers the operation and maintenance of the Timberwolf TW 230HB. All information in this manual is based on the latest product information available at the time of purchase.

All the information you need to operate the machine safely and effectively is contained within this manual.

Ensure that all operators are **properly trained** for operating the TW 230HB, **especially in safe working practices.**

Timberwolf's policy of regularly reviewing and improving our products may involve major or minor changes to this TW 230HB or its accessories. Timberwolf reserves the right to make changes at any time without notice and without incurring any obligation.

Due to improvements in design and performance during production, there may be, in some cases, minor discrepancies between the actual TW 230HB and the text in this manual.

All TW 230HB chippers have a full pre-delivery inspection before leaving the factory and are ready to use.

1.2 Important Health and Safety Information

Before using your new chipper, please take time to read this manual. Failure to do so could result in:

- personal injury.
- equipment damage.
- damage to property.
- 3rd party injuries.



1.3 Warning or Caution Symbols



Warning

Be aware of these symbols and where shown, carefully follow the instructions.



Caution

These symbols indicate important safety messages in this manual. When you see these symbols, be alert to the possibility of injury to yourself or others and carefully read the message that follows.

Always follow safe operating and maintenance practices.

1.4 Hazardous Materials



Caution

The following hazardous materials are present within the TW 230HB:

- Engine oil
- Grease
- Loctite
- Battery acid
- Hydraulic oil
- Coolant
- Diesel
- Copper Ease

MATERIAL SAFETY DATA SHEETS FOR THESE HAZARDOUS MATERIALS ARE AVAILABLE ON REQUEST. REFER TO THESE FOR FIRST AID AND FIRE PROTECTION MEASURES.

Always follow recommended procedures for safe handling, removal and disposal of hazardous materials. Safety precautions should be taken when handling hazardous materials. The use of oil-resistant gloves and safety glasses is recommended. Avoid direct contact with the substance. Store in a cool, well ventilated area. Avoid sources of ignition, strong oxidising agents and strong acids. Ensure hazardous spillages do not flow into the ground or drainage system. Ensure potential environmental damage is controlled safely, according to local laws.

1.5 Purpose

The TW 230HB is designed to chip solid wood material up to 160 mm (6 inches) in diameter and is capable of chipping over 4 tonnes of brushwood per hour.



2 Product Details

This chapter contains the specifications of the TW 230HB.

It shows the locations of the main components of the chipper, lists all the decals used on the machine, and describes the purpose of the various guarding assemblies.

2.1 Specification

The specifications of the TW 230HB are shown in Table 1.

Table 1 - Specifications

Overall Height	2141 mm
Height with Discharge Tube Removed	1496 mm
Overall Length	3766 mm
Length with Feed Tray Folded	3252 mm
Width	1517 mm
Overall Weight	745 Kg
Engine Type	Kubota 4-cylinder diesel
Maximum Power	18.5 kW (24.8 hp)
Cooling Method	Water cooled
Starting Method	Electric
Roller feed	Twin hydraulic motors
Maximum Material Diameter	160 mm (6 inches)
Fuel Capacity	18 litres
Hydraulic Oil Capacity	15 litres
Maximum Material Processing Capacity	4 tonnes/hr
Fuel Type	Diesel



2.2 Location of Parts

2.2.1 Parts Locator 1

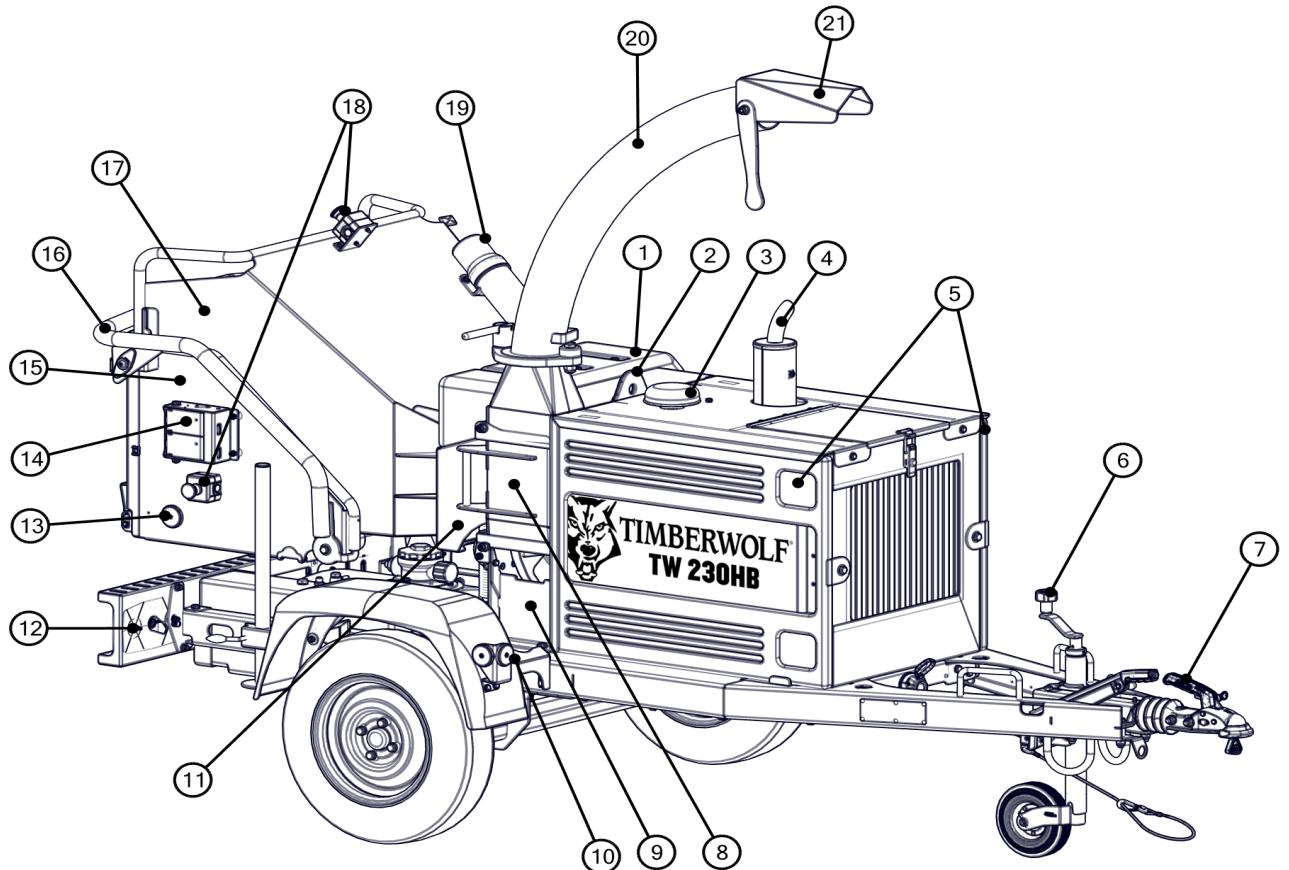

- | | | | |
|----|----------------------------------|----|--------------------------|
| 1 | Roller box guard | 12 | Light board |
| 2 | Lifting eye | 13 | Reflector (both sides) |
| 3 | Air intake | 14 | Control box (both sides) |
| 4 | Exhaust | 15 | Feed tray |
| 5 | Engine bay side panels | 16 | Safety bar |
| 6 | Jockey wheel height adjuster | 17 | In-feed funnel |
| 7 | Tow head | 18 | Emergency stops |
| 8 | Rotor housing blade access hatch | 19 | Manual canister |
| 9 | Rotor housing | 20 | Discharge tube |
| 10 | Reflectors (both sides) | 21 | Discharge bucket |
| 11 | Hydraulic motor guard | | |



2.2.2 Parts Locator 2

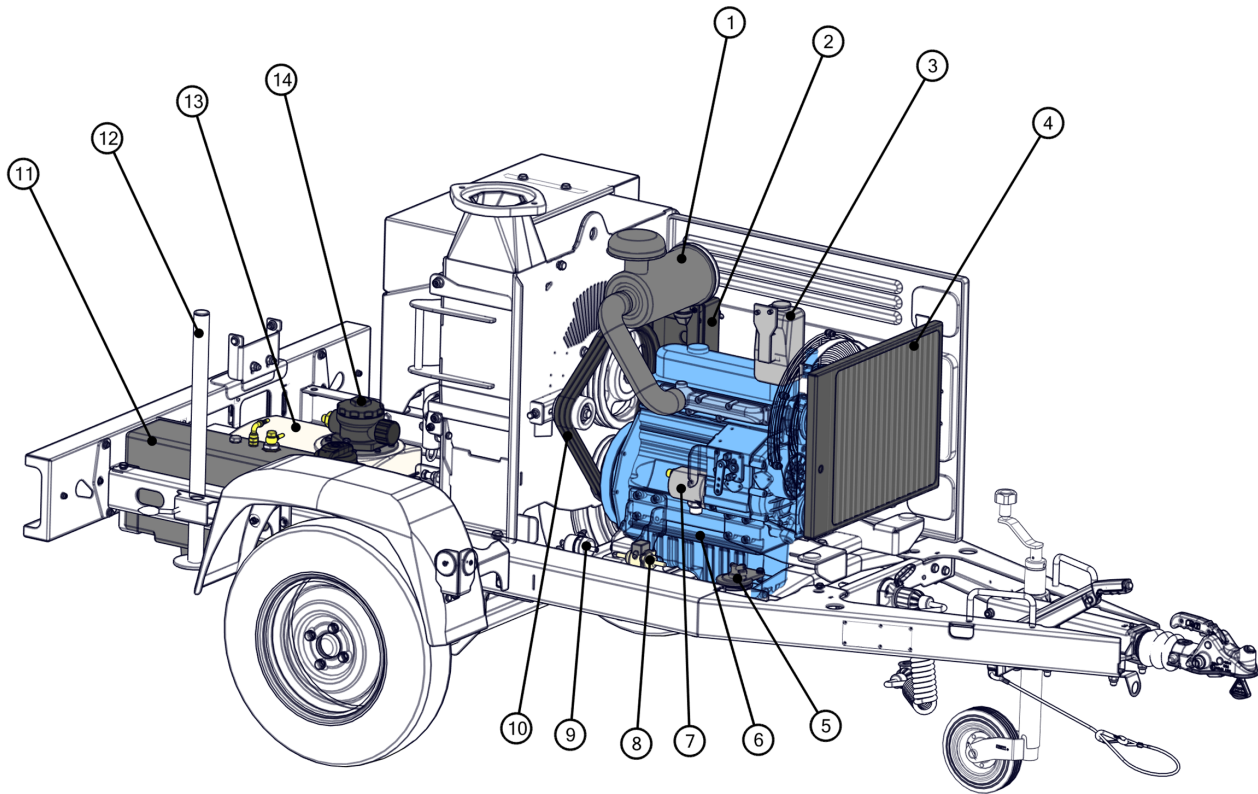

- | | | | |
|---|-------------------------|----|---------------------|
| 1 | Air filter | 8 | Fuel pump |
| 2 | Electric panel | 9 | In-line fuel filter |
| 3 | Radiator expansion tank | 10 | Drive belts |
| 4 | Radiator | 11 | Fuel tank |
| 5 | Fuel filter | 12 | Prop stand |
| 6 | Engine block | 13 | Hydraulic tank |
| 7 | Hydraulic pump | 14 | Hydraulic filter |



2.2.3 Parts Locator 3

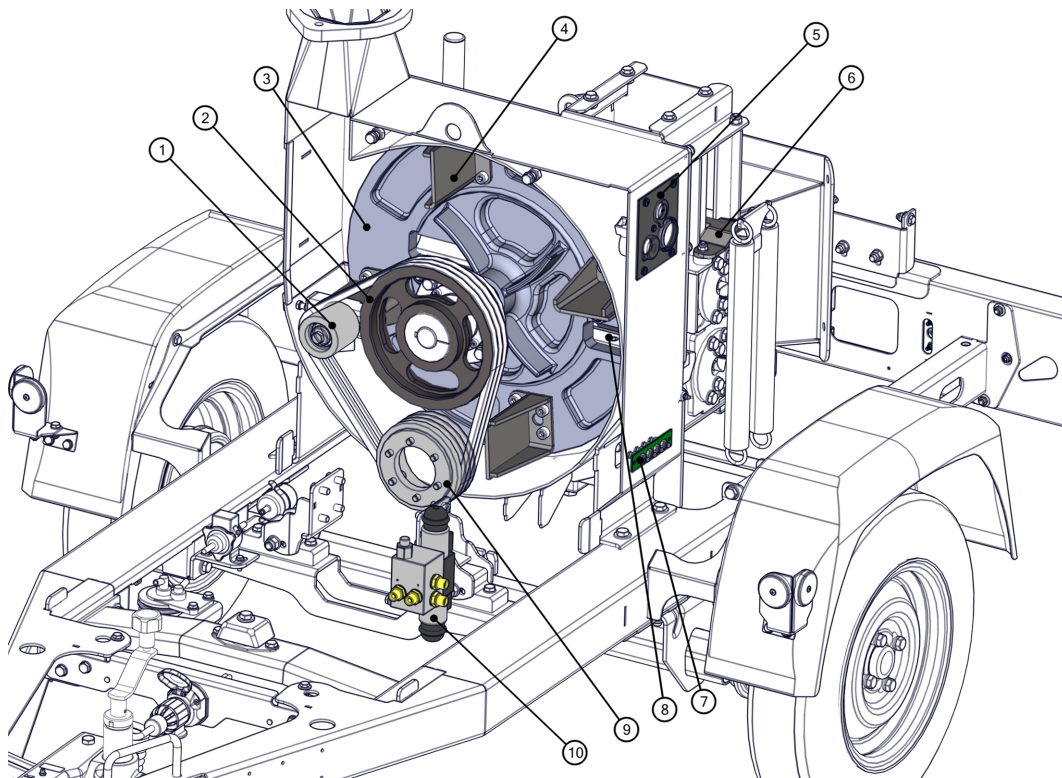

- | | | | |
|---|------------------------|----|---------------------------|
| 1 | Belt tensioning pulley | 6 | Top slide |
| 2 | Rotor pulley | 7 | Greasing point |
| 3 | Rotor | 8 | Cutting blade (x2) |
| 4 | Fan section (x4) | 9 | Drive pulley |
| 5 | Control panel | 10 | Directional control valve |

2.3 Tool Box













The TW 230HB is supplied with a tool box which contains:

- Combination spanner (17mm/19mm)
- Rotor locking tool
- Copper Ease
- Access cover keys (x2)
- Ignition keys (x2)
- Keyring



2.4 Safety Decals

Table 2 - Safety Decal Descriptions

	Pt No	Description
	616	WARNING - Hot exhaust.
	617	WARNING - High velocity discharge. Keep clear.
	4099	DANGER - Rotating blades. Keep hands and feet out.
	C192-0102	DANGER - Do not climb into the feed funnel (Timberwolf Safety Plus Kit).
	C192-0112	Fuel here. Risk of fire. Allow engine to cool for one minute before refuelling. Use diesel fuel only.
	P637	DANGER - Do not operate without this cover in place.
	P650	DANGER - Autofeed system fitted. Rollers may turn without warning. When the engine is switched off the rollers will turn during the run down period.
	P653	DANGER - Rotating blades inside. Stop engine and remove key before removing discharge unit.
	P654	CAUTION - When transporting, discharge clamps may work loose. Check frequently.
	P655	CAUTION - Avoid standing directly in front of feed funnel to reduce exposure to noise, dust and risk from ejected material.
	P656	DANGER - Do not use this machine without the discharge unit fitted. Failure to comply may result in serious injury or damage.
	P3611	DANGER - Rotating blades. Keep hands and feet out (Timberwolf Safety Plus Kit).









2.5 Instruction Decals

Table 3 - Instruction Decal Descriptions

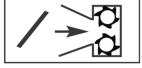
	Pt No	Description
	670	Personal Protective Equipment required. (Section 3.2 "Operator's Personal Protective Equipment (PPE)" on page 17.)
	1258	WARNING - Failure to maintain brake adjustment will result in damper failure. No warranty liability will be accepted on this item.
	1399	Push safety bar to stop.
	1661	Refer to the instruction manual for greasing and maintenance information.
	1662	The instruction manual with this machine contains important operating, maintenance and health and safety information. Failure to follow the information in this instruction manual may lead to death or serious injury.
	2800	Reverse feed.
	2801	Forward feed.
	2949	Lifting eye is designed to lift the machine's weight only. Do not use hoist on lifting eye. Use correctly rated safety shackle only through lifting eye. Lifting eye to be inspected every 6 months and prior to each use. Do not use lifting eye if damaged.
	3022	Clean under blades before refitting or turning. Failure to do so may result in blades coming loose and damage being caused to the rotor housing.
	18393	New drive belts need re-tensioning. When new belts are fitted check tension every 2-3 hours and adjust until tension remains constant.
	19517	WARNING - Do not engage starter motor for more than 20 seconds. Allow one minute before attempting to start. Investigate reasons for failure to start. Excessive cranking will result in starter motor failure. This will not be covered under warranty.
	P652	CAUTION -Do not put road sweepings in machine as grit will damage blades.

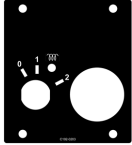







	Pt No	Description
	P691	Do not pull here.
	P729	Throttle setting.
	P1810	Relay decal: Forward latch.
	P1811	Relay decal: Engine safety.
	P1812	Torque blade bolts to 170 Nm (125 ft-lb).
	C192-0203	Engine control panel.
	P1438	Lifting eye maximum weight.



2.6 Model Decals

Table 4 - Model Decal Descriptions

	Pt No	Description
	1363	Timberwolf - Wolf head logo.
	C192-0100	Guaranteed Sound Power Level. (The maximum amount of acoustic energy emitted by the machine.)
	C192-0101	Equivalent Continuous Sound Power Level. (The average amount of acoustic energy an operator is subjected to during normal operations.)
	C192-0191	Timberwolf - Side panel.
	C192-0201	Made in Britain
	C192-0211	Weight below 750Kg - Diesel engine - Right side.
	C192-0218	Weight below 750Kg - Diesel engine - Left side.



2.7 Identification Plate

The Timberwolf TW 230HB Identification Plate is mounted on the front outer face of the right-hand chassis beam. It includes the unique machine Serial Number.

		TIMBERWOLF LTD Entec House, Tomo Industrial Estate, Stowmarket, Suffolk IP14 5AY - UK		
		MODEL _____		
SERIAL NO. _____		GROSS WEIGHT _____		_____ KG
CARR. TYP/SN. _____		DATE _____		0 - _____ KG
NOM. PWR _____				1 - _____ KG
				2 - _____ KG

2.8 Guards



Ensure all the guards are correctly fitted during all operations. The guards may only be removed for maintenance.

The TW 230HB has the following fixed guards for protection of the operator, chipper and environment:

Roller Box Guard

- Protects the rotor housing from damage or foreign matter.
- Protects the operator from injuries from moving rollers or from ejected material during operation.

Hydraulic Motor Guard

- Protects the hydraulic motors from damage.
- Protects the operator from injuries due to heat or movement of the motor.

Rotor Housing Blade Access

- Protects the operator from rotating parts (e.g. cutting blades).
- The interlocking switch prevents the engine from running when the hatch is opened, to stop the chipper from rotating.

Engine Bay Side Panels

- Protect the operator from moving parts (e.g. belts and pulleys), hot surfaces and engine fluids.
- Protect the chipper from ingress of environmental debris.



THIS PAGE INTENTIONALLY LEFT BLANK



3 Safety Notes and Warnings

3.1 Safety Notices



Warning

Indicates a hazardous situation which, if not avoided, could result in death or serious injury.



Caution

Indicates a hazardous situation which, if not avoided, could result in moderate injury or damage the machine.

3.2 Operator's Personal Protective Equipment (PPE)



Caution

DO NOT wear rings, bracelets, watches, jewellery, loose-fitting clothing or any other items that could be caught in the material and draw you into the chipper.

Chainsaw safety helmet (EN 397) fitted with mesh visor (EN 1731) and ear defenders (EN 352).



Work gloves with elasticated wrist.



Steel toe cap safety boots (EN 345-1).



Close-fitting heavy-duty non-slag clothing. High-visibility clothing (EN 471) if risk assessment identifies the need.



Face mask if appropriate.





3.3 Basic Woodchipping Safety



It is the responsibility of the machine operator to carry out a full site Risk Assessment before starting work. This Risk Assessment should consider the following points:

MAINTAIN A SAFETY EXCLUSION ZONE around the chipper of at least 10 metres for the general public or employees without adequate protection. Use hazard tape to identify this working area and keep it clear from debris build up. Chips should be ejected away from any area the general public have access to.

HAZARDOUS MATERIAL - Some species of trees and bushes are poisonous. The chipping action can produce vapour, spray and dust that can irritate the skin. This may lead to respiratory problems or even cause serious poisoning. Check the material to be chipped before you start. Avoid confined spaces and use respiratory protection where necessary.

BE AWARE when the chipper is processing material that is an awkward shape. The material can move from side to side in the funnel with great force. If the material extends beyond the funnel, it may push you to one side. Badly twisted material should be trimmed before being chipped to avoid thrashing in the feed funnel.

BE AWARE that the chipper can eject chips out of the feed funnel with considerable force. Always wear full head and face protection.

ALWAYS work on the side of the machine furthest from any local danger (e.g. not road side).

NEVER leave the chipper unattended when running. Machines must be supervised at all times when in use.

In the event of an accident, stop the machine, remove the key and call the emergency services immediately.



3.4 Operating Safely - You MUST



YOU MUST stop the chipper engine before adjusting, refuelling or cleaning.

YOU MUST check the rotor has stopped rotating and remove the chipper ignition key before maintenance of any kind, or whenever the machine is to be left unattended.

YOU MUST check the machine is well supported, handbrake applied, and cannot move. Use wheel chocks if available. If working on an incline, position on solid ground, across the slope.

YOU MUST operate the chipper with the engine set to maximum speed when chipping.

YOU MUST check (visually) for fluid leaks. If found, resolve the leak before operating the chipper.

YOU MUST take regular breaks. Wearing personal protective equipment for long periods can be tiring and hot.

YOU MUST keep hands, feet and clothing out of feed opening, discharge and moving parts.

YOU MUST use the next piece of material or a push stick to push in short pieces. Under no circumstances should you reach into the funnel.

YOU MUST keep the operating area clear of people and animals.

YOU MUST keep the operating area clear from debris build up.

YOU MUST keep clear of the discharge tube. Material may be ejected with great force.

YOU MUST ensure protective guarding is in place before commencing work. Failure to do so may result in personal injury or loss of life.

YOU MUST operate the chipper in a well ventilated area - exhaust fumes are dangerous.

YOU MUST ensure a fire extinguisher is available on site.

YOU MUST ensure a personal first aid kit and hand cleaning materials are available (e.g. waterless skin cleanser).

3.5 Operating Safely - You MUST NOT



YOU MUST NOT operate the chipper if you are under the influence of any substance (drugs, alcohol) which might impair vision, dexterity or judgement.

YOU MUST NOT operate the chipper unless available light is sufficient to see clearly.

YOU MUST NOT use or attempt to start the chipper without the feed funnel, guards and discharge unit securely in place.

YOU MUST NOT stand directly in front of the feed funnel when using the chipper. Stand to one side (Figure 1).



YOU MUST NOT smoke when refuelling.

YOU MUST NOT climb on the machine at any time .

YOU MUST NOT use the machine if there is any exposed wiring.

YOU MUST NOT use the chipper inside buildings or enclosed spaces.

YOU MUST NOT handle material that is partially engaged in the machine.

YOU MUST NOT let anyone who has not received instruction or training operate the machine.



Figure 1 - Feeding Position



YOU MUST NOT allow any of the following to enter the machine as serious damage is possible:



BRICKS



CLOTH



GLASS



METAL



STONES



PLASTIC



SOIL & ROOTS



ROPE



RUBBER

3.6 Noise Emissions

The TW 230HB has been tested according to BS EN ISO 3744:2010, as required by Annex III of Directive 2000/14/EC “Noise Emission in the Environment by Equipment for Use Outdoors”.

The test was carried out while chipping 120 mm x 120 mm Corsican Pine, 1.5 m in length.

Equivalent Continuous Sound Pressure Level (LAeq) at the operator's position is 96 dB (A).

Guaranteed Sound Power level (LWA) is 118 dB(A).

Prolonged exposure to loud noise may cause permanent hearing loss.

All persons within a 4-metre radius must wear good quality ear protection (EN 352) at all times to prevent possible damage to hearing.



4 Towing and Handling

4.1 Safe Transportation



Warning

DO NOT Ride on the chipper when it is being towed.

- When towing a chipper the maximum rated speed is 96 km/h (60 mph).
- Always comply with the local speed limits and traffic laws.
- On rough or bumpy road surfaces reduce speed accordingly to protect your machine from unnecessary shock or vibration.
- When towing off-road be aware of objects that may catch the chipper under-gear.
- When towing off-road ensure inclination is not excessive.
- Avoid excessively pot-holed ground.
- Take care when reversing the chipper as the short wheel base will react quickly to steering.
- Always check the discharge tube is tight, and pointing directly forwards before moving.
- Keep tyre pressures inflated to 2.2 bar (32 psi).
- Check wheel nuts are tightened to 88 Nm (65 ft-lb).
- Clear loose chippings and debris from the machine before moving.
- Ensure feed funnel is closed and the catches are properly engaged before moving.
- Ensure tow hitch lock mechanism is locked before moving.

4.2 Hitching to the Towing Vehicle

1. Ensure the chipper handbrake is applied before starting the hitching procedure.
2. If wheel chocks are available they should be used for extra security.
3. Check the ball hitch head is well greased.
4. Raise the prop stand and secure in the raised position.
5. Wind the jockey wheel assembly anticlockwise until the tow head is above the height of the ball hitch on the vehicle.
6. Reverse the vehicle so that the ball hitch is directly below the tow head.
7. Attach the breakaway cable to a strong point on the vehicle, NOT to the ball hitch.
8. Grasp the handle on the tow head and push back the catch with thumb.
9. Wind the jockey wheel assembly clockwise, to lower the tow head onto the ball hitch.
10. Release the handle and continue to wind the jockey wheel clockwise until the tow head snaps into place on the ball hitch.



11. Wind the jockey wheel anticlockwise until it begins to raise the rear of the towing vehicle.
12. If the tow head fails to raise the rear of the vehicle, but instead moves clear of the ball hitch, repeat from Step 8 to Step 11.
13. Wind the jockey wheel up until it is fully retracted and the jockey wheel frame is seated in its notch on the stem. The chipper weight should be fully on the vehicle.
14. Check the jockey wheel handle is secure before transportation. Do not over-tighten the jockey wheel handle.
15. Release the jockey wheel clamp and slide the jockey wheel assembly fully up.
16. Tighten the clamp on the jockey wheel assembly.
17. Connect the electrical plug to the socket on the rear of the towing vehicle.
18. Ensure the correct registration plate is fitted to the rear of the trailer.
19. Carry out a full functional check of all the trailer and towing vehicle lights for correct operation.
20. The chipper is now correctly attached to the towing vehicle.
21. If chocks were used, remove them from the wheels.
22. Release the chipper handbrake.

4.3 Unhitching from the Towing Vehicle

1. Ensure the chipper is positioned on a level, stable surface.
2. Ensure the chipper handbrake is applied before starting the unhitching procedure.
3. If wheel chocks are available they should be used for extra security.
4. Disconnect the electrical cable from the vehicle socket and stow in the dock provided on the chassis when not in use.
5. Release the breakaway cable and secure in a safe location on the chassis.
6. Release the jockey wheel assembly clamp.
7. Lower the jockey wheel assembly fully.
8. Tighten the clamp on the jockey wheel assembly.
9. Wind the jockey wheel assembly anticlockwise until it starts to take the weight of the chipper.
10. Grasp the handle on the tow head and push back the catch with thumb.
11. Continue to wind the jockey wheel assembly anticlockwise until the tow head is lifted clear of the ball hitch.
12. Drive the vehicle clear of the chipper.
13. Wind the jockey wheel assembly either clockwise or anticlockwise until the chipper is level.
14. Lower the prop stand and secure in the lowered position to ensure the chipper remains level.
15. The chipper is now correctly detached from the towing vehicle.



4.4 Stabilising the Chipper

To reduce the risk of accidents, the chipper must be kept in a stable position at all times.

Hitched to a vehicle

The chipper handbrake should be released. The prop stand and jockey wheel should be stored in the towing position (Figure 2).

Unhitched and ready for operation

The chipper must be made level and secure by applying the handbrake, lowering the prop stand and jockey wheel. If wheel chocks are available they should be used for extra security. (Figure 3).

Unhitched and stored

The chipper must be made level and secure by applying the handbrake, lowering the prop stand and jockey wheel. (Figure 3).

For prolonged storage the handbrake may be left released, providing the chipper is prevented from moving by the use of wheel chocks.

The discharge tube must be pointing towards the tow head.

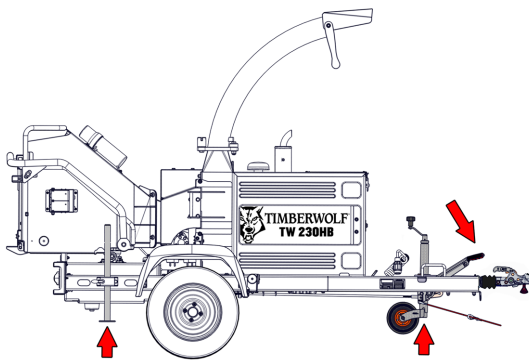

Figure 2 - Chipper in Towing Configuration

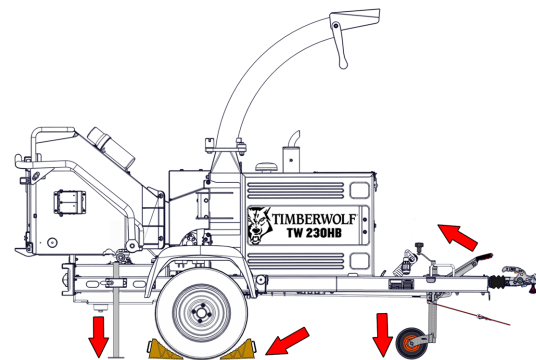

Figure 3 - Chipper in Unhitched Configuration



THIS PAGE INTENTIONALLY LEFT BLANK



5 Operating Instructions

WARNING

DO NOT USE OR ATTEMPT TO START THE CHIPPER WITHOUT THE PROTECTIVE GUARDING AND DISCHARGE TUBE SECURELY IN PLACE. FAILURE TO DO SO MAY RESULT IN PERSONAL INJURY OR LOSS OF LIFE.

5.1 Manual Controls

Manual controls are located on the feed tray, where they are easily accessible by the operator during chipping.

Infeed Control Boxes

A control box is located on either side of the feed tray, containing two controls (Figure 4, Item 2).

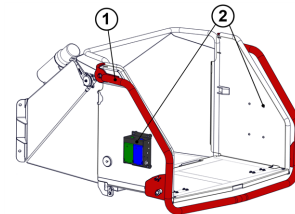

Figure 4 - Manual Control Positions

Forward Feed Control (Figure 5)

Press the **GREEN** control to start the in-feed rollers turning in the forward direction, if the engine speed is high enough (Refer to Section 5.2 "No Stress Control" on page 26). This allows you to feed material into the chipper.

When the control is released, the in-feed rollers will continue to turn.

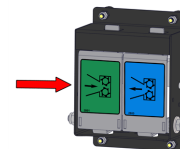

Figure 5 - Forward Feed Control

Reverse Feed Control (Figure 6)

Press the **BLUE** control to reverse the direction of the in-feed rollers. This allows you to back material out of the chipper.

The in-feed rollers will only operate in reverse while the control is held in.

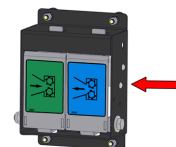



Figure 6 - Reverse Feed Control



Red Safety Bar

	<p style="text-align: center;">WARNING</p> <p style="text-align: center;">DO NOT REMOVE, JAM, DISABLE, BYPASS, OVER-RIDE OR OTHERWISE IMPEDE THE OPERATION OF THE RED SAFETY BAR.</p>	
---	---	---

The large red safety bar surrounds the feed tray and sides of the feed funnel (Figure 4, Item 1). It is spring-loaded and operates a switch to interrupt the power to the rollers. The switch will only activate if the bar is pushed to the limit of its travel. The rollers stop instantly.

To start the rollers again, press the **GREEN** forward or **BLUE** reverse feed control.

To engage the control system, the red safety bar must be activated once before each work session. (Refer to Section 5.9 "In-feed and Emergency Stop Safety Tests" on page 29.)



Do not rely solely on the red safety bar to keep the roller stationary. Always switch off the machine and remove the ignition key before approaching the roller.

5.2 No Stress Control

The 'No Stress' function prevents excessive loads being placed upon the engine when feeding larger material into the chipper.

If the engine speed drops below a pre-set level, the 'No Stress' function will stop the feed rollers from turning in the forward direction until the engine speed recovers to normal.

The rollers can still be operated in the reverse direction.



With the 'No Stress' function in operation, the rollers may begin to turn again without any warning.

5.3 Emergency Stopping

In an emergency, the TW 230HB can be stopped using the following method(s):

Red Safety Bar

Pushing on the Red Safety Bar will immediately stop the feed rollers from rotating. The engine will continue to run and the rotor will continue to turn.

The rollers can be restarted by pushing either the **GREEN** forward, or the **BLUE** reverse feed controls.

Emergency Stop Button

Pushing any one of the Emergency Stop Buttons on the top of the funnel, or either side of the feed tray, will remove all power to the engine AND the feed rollers,



bringing the whole machine to a complete stop.

The engine cannot be restarted until the operated Emergency Stop Button is reset and the main ignition switch is turned off to reset the machine.

5.4 Discharge Controls

Controlling the direction and angle of the discharge is an essential part of operating the chipper in a safe manner.

Discharge Direction

1. Slacken the locking nut using the integral handle (Figure 7).
2. Rotate the discharge tube to face in a safe direction.
3. Re-tighten the locking nut.

Discharge Angle

Use the handle to adjust the bucket to achieve a safe discharge angle (Figure 8).

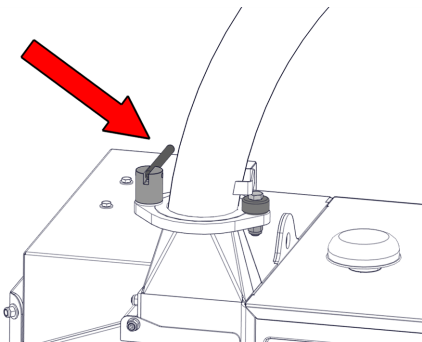

Figure 7 - Discharge Tube Locking Nut

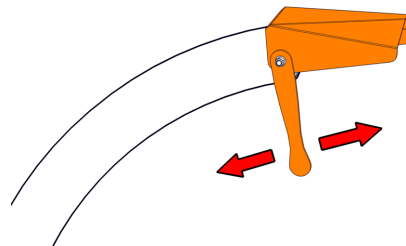

Figure 8 - Discharge Bucket

5.5 Engine Controls

On the TW 230HB the engine controls are divided between two separate locations.

The engine ignition is on the control panel, in the centre of the machine, forward of the feed funnel on the left side.

The throttle lever is on the left side of the feed funnel, at the top rear corner (Figure 9).



Caution

In cold weather, to prevent damage, ensure that the throttle lever is not frozen before attempting to move it.

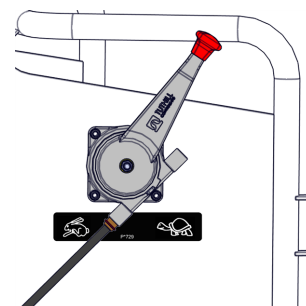

Figure 9 - Throttle Lever



5.6 Checks Before Starting

The following check list should be carried out daily, before starting the chipper and whenever the chipper is moved to a new location.

1. ENSURE the chipper is located on firm, level ground.
2. ENSURE the chipper is well supported and cannot move. (Refer to Section 4.4 "Stabilising the Chipper" on page 23.)
3. If the chipper remains hitched to the tow vehicle, ENSURE the vehicle is safely secured and isolated prior to operation of the chipper.
4. ENSURE all guards are securely fitted.
5. ENSURE the discharge tube is in place, fastened securely and pointing in a safe direction. (Refer to Section 5.4 "Discharge Controls" on page 27.)
6. ENSURE there are no objects in the feed funnel.
7. ENSURE the feed tray is in the up position to prevent people reaching the rollers.
8. CHECK for any visible signs of fluid leaks.
9. CHECK fuel and hydraulic levels are correct. (Refer to Section 5.15 "Check Hydraulic Oil Level" on page 33, and Section 5.16 "Check Fuel Level and Refuel" on page 33.)

5.7 Starting the Engine



Do not engage the starter motor for more than 20 seconds. Allow a minimum of one minute to elapse before attempting to start again.

1. Ensure the throttle lever is in the slow (tortoise) position (Figure 10).
2. Insert the ignition key in the control panel and turn to position 1 (Figure 11).
3. Confirm that the heater LED comes on (Figure 11).
4. Wait until the heater LED goes out.
5. Turn the ignition key to the start position (2) (Figure 11).
6. Release the ignition key as soon as the engine starts.

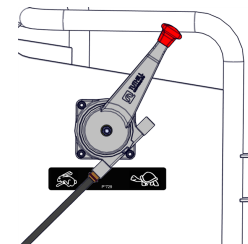

Figure 10 - Throttle Lever

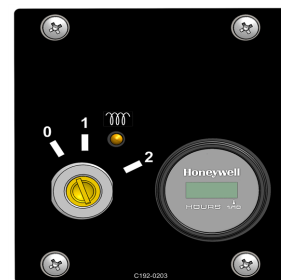

Figure 11 - Control Panel



5.8 Controlling the Engine Speed

The TW 230HB must always be run at full speed when chipping.

Move the throttle lever all the way to the fast (hare) position and ensure the engine is running at full speed before starting to chip (Figure 12).

If no chipping is to be carried out for more than a few minutes, move the throttle lever back to the slow (tortoise) position, to reduce stress on the engine.

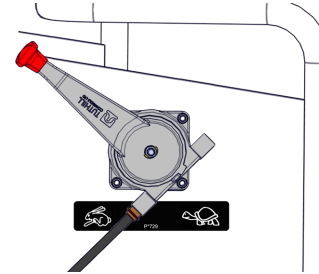

Figure 12 - Throttle lever

5.9 In-feed and Emergency Stop Safety Tests



Warning

Before starting to chip, it is essential that the In-feed and Emergency Stop safety circuits are confirmed to be working. Failure of either safety circuit could prevent the in-feed rollers from being stopped in an emergency, resulting in serious injury or death.



Warning

If the machine fails any part of the Emergency Stop System Checks it must not be used until the problem is rectified.

The Emergency Stop devices are mounted on the sides of the feed tray and on top of the feed funnel.

For the exact locations of all the Emergency Stop devices refer to Parts Locator 1.

1. Ensure the engine is running at full speed.
2. Lower the feed tray to the working position.
3. Press the red safety bar, ensuring that it operates freely and smoothly and that the safety switch (left side of tray) is free from debris and is being activated by the movement of the bar.
4. Press the **GREEN** Forward Feed Control (Figure 13).
 - The in-feed rollers should turn forwards.
 - The rollers should continue to turn after the control is released.
5. Press the Red Safety Bar (Figure 14).
 - The in-feed rollers should stop turning.
6. Press the **BLUE** Reverse Feed Control (Figure 15).
 - The in-feed rollers should turn backwards while the **BLUE** feed control is held in.
 - The rollers should stop turning when the control is released.

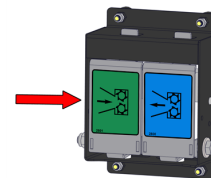

Figure 13 - Forward Feed Control

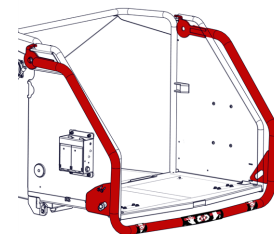

Figure 14 - Red Safety Bar



7. Move to the opposite side of the feed funnel and repeat steps 4 to 6, to confirm both sets of Feed Controls operate correctly.
8. Check all Emergency Stops for visible damage and debris (including wiring).
9. Press the **GREEN** Forward Feed Control to activate the forward rollers.
10. Press one of the Tray-mounted side Emergency Stops or the Funnel-mounted top Emergency Stops (Figure 16). The switch chosen should be varied each time the machine is used.
 - The forward rollers should stop immediately and the whole machine should come to a complete stop.
 - Check that the button operates correctly and cleanly.
11. Reset the Emergency Stop by turning it to release.
 - Check that the button resets correctly and cleanly.
 - Resetting the Emergency Stop should not cause the engine to restart.
12. Ensure the engine starts and will run at full speed.

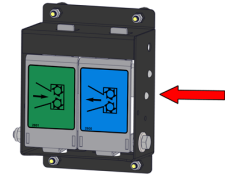

Figure 15 - Reverse Feed Control

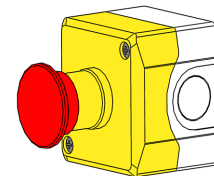

Figure 16 - Emergency Stop Switch

N.B. All Emergency Stops are required to be tested together as part of the Monthly Checks defined in Section 5.1 of the Service & Warranty Record. If the Operator is unsure whether these checks have been carried out then they should check every Emergency Stop fitted to the machine by repeating Steps 8 to 12. A minimum of 30 seconds should be left between each test.



5.10 Chipping

When all the safety checks have been completed and the engine is running at full speed, chipping can be started.

Press and release the **GREEN** Forward Feed Control. The in-feed rollers will start to turn in the forward direction. Commence feeding material into the chipper.

Wood up to 160 mm (6 inches) in diameter can be fed into the feed funnel. Put the butt end in first and engage it with the feed rollers. Cutting a chamfered edge on the butt end can assist the rollers in gripping and loading the material. The hydraulic feed rollers will pull the material into the machine quite quickly. Large diameter material will have its feed rate automatically controlled by the No Stress unit. (Refer to Section 5.2 "No Stress Control" on page 26.)

Sometimes a piece of wood that is a particularly awkward shape may be too strong for the feed rollers to grip. This will cause the top roller to either bounce on the wood, or both rollers to stall. If this occurs, press the **BLUE** reverse feed control until the material is released. Safely retrieve the material from the feed funnel and trim it so that the chipper can process it.

The two feed rollers should always turn at the same speed. If one or both rollers stop or suddenly slow down it may be that a piece of wood has become stuck behind one of the rollers. If this occurs, press the **BLUE** reverse feed control and hold for two seconds - then press the **GREEN** forward feed control. This should enable the rollers to free the stuck material and continue rotating at the correct speed. If the rollers continue to stall in either the forward feed or reverse feed position, press the red stop button, switch off the engine, remove the ignition key and investigate further.

5.11 Working in Dusty Conditions



Restricted airflow through the radiator may cause the engine to overheat, leading to damage or failure.

When working in an environment that produces a lot of dust, the radiator and the front grille should be checked at regular intervals to ensure they remain clear and allow full airflow through the radiator.

Ensure that the air intake remains clear and allows full air flow.

5.12 Stopping the Engine

1. Move the throttle lever to the slow (tortoise) position and ensure that the engine speed reduces to idle.
2. Allow the engine to run at idle for a minimum of one minute.
3. Turn the ignition key to position 0. The engine should stop within a few seconds.
4. Remove the ignition key.



5.13 Blockages



Do not reach into any section of the chipper whilst it is running. Never reach into the rotor housing with unprotected hands. There are sharp blades and any movement of the rotor may cause serious injury.

If chips stop coming out of the discharge tube, IMMEDIATELY STOP FEEDING MATERIAL IN AND TURN OFF THE ENGINE. Feeding more material into a blocked machine will compact the blockage, making it much harder to clear and possibly damaging the machine.

1. Ensure the chipper is in a safe condition. (Refer to Section 6.1 "Safe Maintenance" on page 35.)
2. Remove the discharge tube and check that it is not obstructed.
3. Remove the blade access hatch.
4. Wearing gloves, reach into the rotor housing and remove as much of the debris causing the blockage as possible.
5. Carefully rotate the rotor to ensure all debris has been removed.
6. Refit the blade access hatch.
7. Refit the discharge tube.
8. Restart the engine and increase to full speed.
9. Allow the machine time to clear any remaining debris from the rotor housing.
10. Feed in a small piece of brushwood and confirm it is ejected correctly.
11. If the machine appears to still be blocked, repeat the process.

5.14 Blade Wear

The TW 230HB has two blades, 135 mm (5 inches) long, hollow ground to a radius of 75mm, and 100 mm wide when new. A new blade will chip for up to 25 hours before requiring sharpening. This will significantly reduce if the machine is fed with stony, sandy or muddy material.

A blunt blade has reduced performance, putting greater stress and load on the machine and producing irregular or stringy chips.

Ensure the blade edge is sharp and free from chips. If the blade is blunt, or damaged, rotate or change it. When both sides of the blade are blunt it should be sent to a reputable blade sharpening company.

A blade can be sharpened several times, providing it does not exceed the wear mark which indicates the safe limit (Figure 17).

The static anvil should also be checked and replaced if worn, as cutting performance will be reduced, even if sharp blades are fitted.

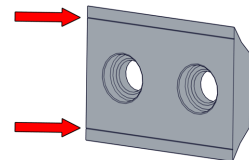

Figure 17 - Blade wear marks



5.15 Check Hydraulic Oil Level

The hydraulic oil level is visible through the side of the tank. The level should be between the 'Max' and 'Min' markings on the tank (Figure 18).

To replenish, refer to Section 6.11 "*Change Hydraulic Oil and Filter*" on page 45.

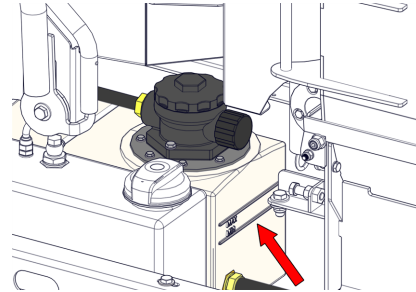

Figure 18 - Hydraulic Oil Level Indicator

5.16 Check Fuel Level and Refuel



Caution

Always follow standard Health and Safety procedures.

The fuel level is visible through the side of the tank. To replenish, follow this process:

- Stop the engine and allow it to cool before refuelling.
- Never smoke or allow naked flames nearby while refuelling.
- Store fuel away from vapour ignition sources such as fires or people smoking.
- Never refuel at the operating location, move to a distance > 10 m to avoid creating fire hazards.
- Fuel storage containers must not be transported in the feed funnel.
- Fuel storage containers must be approved for appropriate fuel storage and clearly labelled, with securely fitting caps.
- Clean the area around the fuel cap and use a funnel for refuelling. Replace the fuel cap securely.
- Avoid skin contact with fuel. If fuel enters the eyes, wash out with sterile water immediately and seek medical advice as soon as possible.
- Always clean up spillages quickly. If fuel is spilt on clothing, change clothes before returning to the work area.





5.17 Troubleshooting

Problem	Cause	Solution	Caution - Always ensure appropriate PPE is worn	
Wood chip ejection stopped / limited	Obstructed discharge	Clear debris from discharge chute.		Ensure machine is off and keys removed.
	Loose drive belts	Tension belts. (Refer to Section 6.9 "Adjust Rotor Drive Belt Tension" on page 43.)		Ensure machine is off and keys removed.
	Damaged chipping components	Inspect chipping components. Replace broken or missing components.		Ensure machine is off and keys removed. Call engineer for repair.
	Chipping blades dull	Rotate, sharpen or replace blades. (Refer to Section 6.8 "Change Blades" on page 41.)		Ensure machine is off and keys removed.
	Anvils dull	Check anvil has sharp edge. Rotate or replace if necessary.		Ensure machine is off and keys removed.
Rotor does not turn	Obstructed discharge	Clear debris from discharge chute.		Ensure machine is off and keys removed.
	Rotor jammed	Inspect & clear infeed funnel, roller box & rotor housing.		Ensure machine is off and keys removed.
	Drive belt issue	Inspect drive belts, replace if required. Tension belts (Refer to Section 6.9 "Adjust Rotor Drive Belt Tension" on page 43.)		Ensure machine is off and keys removed.
Slow or not feeding	Low engine speed	Check & inspect throttle & cable. Check throttle is set to specified speed.		Ensure machine is off and keys removed.
	Infeed rollers jammed	Inspect & clear infeed funnel, roller box & rotor housing.		Ensure machine is off and keys removed.
	Hydraulic oil	Check hydraulic oil level and that correct grade of oil is used. Replenish if necessary. (Refer to Section 6.11 "Change Hydraulic Oil and Filter" on page 45.)		Ensure machine is off, cool & pressure has dissipated.
	Roller blades dull	Sharpen blades or replace rollers.		Ensure machine is off and keys removed.
	Obstructed discharge	Clear debris from discharge chute.		Ensure machine is off and keys removed.



6 Maintenance Instructions



THE FOLLOWING PAGES DETAIL ONLY BASIC MAINTENANCE GUIDELINES SPECIFIC TO YOUR CHIPPER.



THIS IS NOT A WORKSHOP MANUAL

The following guidelines are not exhaustive and do not extend to generally accepted standards of engineering/mechanical maintenance that should be applied to any piece of mechanical equipment and the chassis to which it is mounted.

Authorised Timberwolf service agents are fully trained in all aspects of total service and maintenance of Timberwolf wood chippers. You are strongly advised to take your chipper to an authorised agent for all but the most routine maintenance and checks.

Timberwolf accepts no responsibility for the failure of the owner/user of Timberwolf chippers to recognise generally accepted standards of engineering/mechanical maintenance and apply them throughout this machine.

The failure to apply generally accepted standards of maintenance, or the performance of inappropriate maintenance or modifications, may invalidate warranty and/or regulatory compliance, in whole or in part.

Please refer to your Timberwolf service agent for service and maintenance.

6.1 Safe Maintenance



WARNING

ALWAYS IMMOBILISE THE ENGINE BEFORE UNDERTAKING ANY MAINTENANCE WORK ON THE CHIPPER, BY REMOVING THE KEY AND DISCONNECTING THE BATTERY. ENSURE THE CHIPPER IS STABLE BEFORE PERFORMING ANY MAINTENANCE.



- The cutting blades are extremely sharp and should be handled with extreme caution. Always wear gloves when handling the blades.
- The rotor locking tool should be fitted while changing blades, to prevent unexpected movement of the rotor.
- The major components of the Timberwolf are heavy. Lifting equipment must be used for disassembly.
- Clean machines are safer and easier to maintain.
- Avoid contact with hazardous materials.



6.2 Routine Servicing



Warning

Before carrying out any servicing, always ensure the chipper is in a safe condition. (Refer to Section 6.1 "*Safe Maintenance*" on page 35.)

To ensure that your TW 230HB is always maintained in good working order, checks should be carried out at the specified intervals.

Daily servicing is detailed within this manual. (Refer to Section 6.2.1 "*Daily Servicing*" on page 36.)

A series of checks to be carried out at more extended intervals are detailed within the 'Service and Warranty' document.

6.2.1 Daily Servicing

The following checks should be carried out every day:

- Check coolant level.
- Check radiator is clear.
- Check hydraulic oil level - top up if necessary. (Refer to Section 5.15 "*Check Hydraulic Oil Level*" on page 33.)
- Check engine oil - top up if necessary.
- Check for engine oil / hydraulic leaks. (Refer to Section 6.12 "*Check Hoses*" on page 45.)
- Check fuel level. (Refer to Section 5.16 "*Check Fuel Level and Refuel*" on page 33.)
- Check feed funnel, feed roller cover, access covers, engine covers and discharge unit are securely fitted.
- Check blades and change if necessary. (Refer to Section 5.14 "*Blade Wear*" on page 32 and Section 6.8 "*Change Blades*" on page 41.)
- Clean air filter element (Depending on working environment).
- Check tyre pressure is 2.2 bar (32 psi).
- Check safety bar mechanism.
- Check for tightness: all nuts, bolts and fastening. Ensure nothing has worked loose. (Refer to Section 6.7 "*Check and Replace Fasteners*" on page 40.)
- Grease the roller box slides. (Refer to Section 6.14 "*Grease the Roller Box Slides*" on page 46.)
- Grease the roller splines and bearings. (Refer to Section 6.15 "*Grease the Roller Splines and Rotor Bearings*" on page 47.)

6.3 Spares

Only fit genuine Timberwolf replacement parts, such as blades, screws and tanks etc. Failure to do so may result in the invalidation of the warranty and may result in damage to the TW 230HB, personal injury or even loss of life.



6.4 Engine Servicing

All engine servicing must be performed in accordance with the Engine Manufacturer's Handbook provided with the machine.

Failure to adhere to this may invalidate warranty and/or shorten engine life.

6.5 Safe Lifting of the Chipper



The lifting eye on the TW 230HB is only designed to lift the machine's weight for loading, unloading, etc. It is NOT designed to support the machine during maintenance activities. Do not use the hoist hook directly on the lifting eye; use a correctly rated safety shackle.

The lifting eye should be inspected by a competent person prior to each use. **DO NOT USE THE LIFTING EYE IF IT IS DAMAGED.**

The maximum lift weight is 850 Kg, as indicated on the machine.

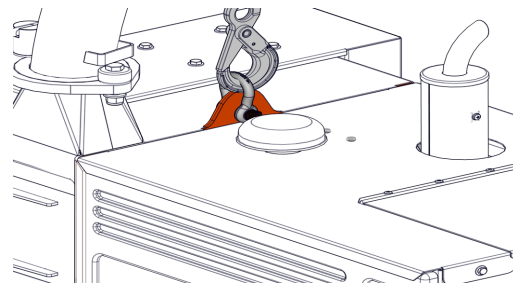











Figure 19 - Lifting Eye and Shackle



6.6 Battery Safety Information

Warning Notes and Safety Regulations for Filled Lead-Acid Batteries

	<ul style="list-style-type: none">• For safety reasons, wear eye protection when handling a battery.		Explosion hazard <ul style="list-style-type: none">• A highly explosive gas mixture is produced when batteries are charged		First aid <ul style="list-style-type: none">• Rinse off acid splashed in the eyes immediately for several minutes with clear water. Remove contact lenses if worn and continue rinsing. Consult a doctor immediately.
	<ul style="list-style-type: none">• Keep out of reach of children				
	<ul style="list-style-type: none">• Avoid causing sparks when dealing with cables and electrical equipment, and beware of electrostatic discharges.• Avoid short circuits		Corrosive hazard <ul style="list-style-type: none">• Battery acid is highly corrosive• Wear protective gloves and eye protection• Do not tilt the battery; acid may escape from vent openings.		<ul style="list-style-type: none">• Neutralise acid splashes on the skin or clothes immediately with acid neutraliser (soda) or soap suds. Rinse with plenty of water.
	Warning notes. The battery case can become brittle. To avoid this: <ul style="list-style-type: none">• Do not store batteries in direct sunlight.• Discharged batteries may freeze. Store in an area free from frost.		Disposal <ul style="list-style-type: none">• Dispose of old batteries at an authorised collection point.• Never dispose of old batteries in household waste		<ul style="list-style-type: none">• If acid is swallowed, consult a doctor immediately.
					

1 Storage and Transport

- Batteries are filled with acid.
- Always store and transport batteries upright and prevent from tilting so that no acid can escape.
- Store in a cool, dry place.
- Do not remove the protective cap from the positive terminal.
- Run a First In, First Out (FIFO) warehouse management system.

2 Initial Operation

- The batteries are filled with acid at a density of 1.28 g/ml during the manufacturing process and are ready to use.
- Recharge in case of insufficient starting power (See Item 4).

3 Installation in the Vehicle and removal from the Vehicle

- Switch off the engine and all electrical equipment.
- When removing, disconnect the negative terminal first.
- Avoid short circuits caused by tools, for example.
- Remove any foreign body from the battery tray and clamp battery tightly after installation.
- Clean the terminals and clamps, and lubricate slightly with battery grease.
- When installing, first connect the positive terminal and check the terminal clamps for tight fit.
- After fitting the battery to the vehicle, remove the protective cap from the positive terminal and place it on the terminal of the replaced battery in order to prevent short circuits and possible earths.



- Use parts from the replaced battery, such as the terminal covers, elbows, vent pipe connection and terminal holders (where applicable). Use available or supplied filler caps.
- Leave at least one vent open, otherwise there is a danger of explosion. This also applies when old batteries are returned.

4 Charging

- Remove the battery from the vehicle; disconnect the lead of the negative terminal first.
- Ensure good ventilation.
- Use suitable direct current chargers only.
- Connect the positive terminal of the battery to the positive output of the charger. Connect the negative terminal accordingly.
- Switch on the charger only after the battery has been connected, and switch off the charger first after charging has been completed.
- Charging current recommendation: 1/10 ampere of the battery capacity Ah.
- Use a charger with a constant charging voltage of 14.4V for recharging.
- If the acid temperature rises above 55 degrees Celcius, stop charging.
- The battery is fully charged when the charging voltage has stopped rising for two hours.

5 Maintenance

- Keep the battery clean and dry.
- Use a moist anti-static cloth only to wipe the battery, otherwise there is a danger of explosion.
- Do not open the battery.
- Recharge in case of insufficient starting power (See Item 4).

6 Jump Starting

- Use the standardised jumper cable in compliance with DIN 72553 only, and follow the operating instructions.
- Use batteries of the same nominal voltage only.
- Switch off the engines of both vehicles.
- First connect the two positive terminals (1) and (2), then connect the negative terminal of the charged battery (3) to a metal part (4) of the vehicle requiring assistance, away from the battery. Start the engine of the vehicle providing assistance, then start the engine of the vehicle requiring assistance, for a maximum of 15 seconds.
- Disconnect the cables in the reverse sequence (4,3,2,1).

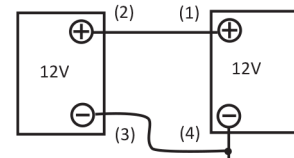

7 Taking the Battery out of Service

- Charge the battery. Store in a cool place or in the vehicle with the negative terminal disconnected.
- Check the battery state of charge at regular intervals, and correct by recharging when necessary (See Item 4).



6.7 Check and Replace Fasteners

Timberwolf recommend that any nuts or bolts which are disturbed during the course of operation or maintenance should be inspected by the operator for signs of wear or stress. If any doubt exists over the serviceability of the fasteners then they should be replaced with new items to the same specification. Use only Timberwolf fasteners, as they are of a higher grade. Failure to use the appropriate grade may result in damage, injury or death.

The Timberwolf TW 230HB is subject to large vibrations during the normal course of operation.

All fasteners must be periodically checked to ensure they have not worked loose. They should be tightened to the correct torque, using a calibrated torque wrench. (Refer to Table 5.)



An uncalibrated torque wrench may be inaccurate by as much as 25% and result in fasteners being either too loose, or overtightened.

Table 5 - Torque Wrench Settings

	Size	Pitch	Head	Torque	
				Nm	ft-lb
Blade Nuts	M16	Standard	24 mm Hex	170	125
Anvil Bolts	M12	Standard	M12 Cap	88	65
General	M8	Standard	13 mm Hex	27	20
General	M10	Standard	17 mm Hex	61	45
General	M12	Standard	19 mm Hex	88	65
Tow Head	M12	Standard	24 mm Hex	88	65
Fuel Tank Feed Line	1/4" BSP	-	19 mm Hex	20	15
Fuel Tank Drain Plug	3/8" BSP	-	22 mm Hex	20	15
Hydraulic Tank Feed Line	1/4" BSP	-	19 mm Hex	20	15
Hydraulic Tank Drain Plug	3/8" BSP	-	22 mm Hex	20	15
Wheel Nuts	M12	Standard	19 mm Hex	88	65



6.8 Change Blades



WARNING

SHARPEN BLADES ON A REGULAR BASIS. FAILURE TO DO SO WILL REDUCE PERFORMANCE, OVERLOAD THE ENGINE AND BEARINGS, AND CAUSE MACHINE BREAKDOWN. BLADES MUST NOT BE SHARPENED BEYOND THE WEAR MARK. FAILURE TO COMPLY WITH THIS COULD RESULT IN MACHINE DAMAGE, INJURY OR LOSS OF LIFE.

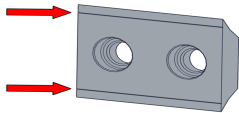



Caution

Wear appropriate gloves for the blade changing operation. Always hold the blades by the flat edges.



Caution

Take care when turning the rotor as fingers may be trapped by the fan paddles, causing serious injury.

1. Ensure the chipper is in a safe condition. (Refer to Section 6.1 "Safe Maintenance" on page 35.)
2. Remove the drive belts to allow the rotor to be turned. This also prevents possible injury due to the engine compression suddenly moving the rotor. (Refer to Section 6.9 "Adjust Rotor Drive Belt Tension" on page 43.)
3. Remove the two nuts and washers retaining the rotor housing blade access hatch and remove the hatch (Figure 20).

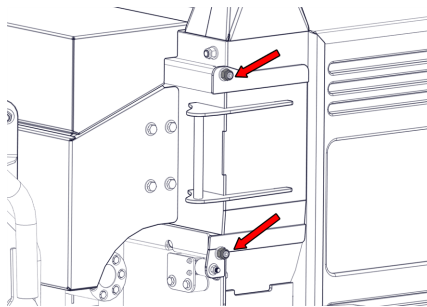

Figure 20 - Rotor Housing Access Hatch

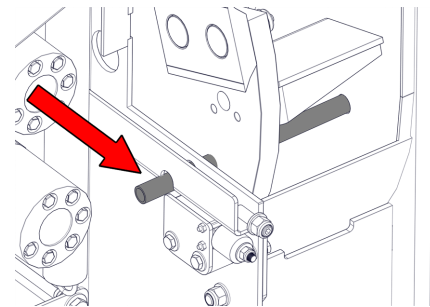

Figure 21 - Locking Bar Inserted

4. Turn rotor to the blade change position.
5. Insert locking bar through rotor housing and rotor (Figure 21).
6. Brush clean the rotor and blade.
7. Using a 24 mm spanner or socket, remove the Nyloc nuts and washers from the blade retaining bolts.
8. Hold the blade in place and remove the two retaining bolts.
9. Withdraw the blade.
10. The blade may be rotated to use the second edge, or replaced with a new or sharpened blade.



11. Thoroughly clean the mating surfaces of the blade and the rotor. **Any material left between the blade and rotor will cause the blade to become loose very quickly.**
12. Ensure that the mounting bolts and nuts are suitable for re-use. (Refer to Section 6.7 "*Check and Replace Fasteners*" on page 40.) If any doubt exists, use new items.
13. Apply a smear of anti-seize compound (copper ease) to the bolt threads and back face of the nuts. **DO NOT** apply copper ease to the counter-bore faces of the blades or bolts.
14. Fit the blade to the rotor using the retaining bolts, washers and Nyloc nuts. The use of genuine Timberwolf blades and bolts is recommended (Figure 22).
15. Tighten the blade bolts to the correct torque setting. (Refer to Section 6.7 "*Check and Replace Fasteners*" on page 40.)
16. Remove the locking bar from the rotor housing and the rotor. Rotate the rotor until the next blade is visible through the access hatch and repeat from step 5 onwards.
17. Refit the rotor housing blade access hatch and the retaining nuts and washers.
18. Tighten the hatch retaining nuts to the correct torque setting. (Refer to Section 6.7 "*Check and Replace Fasteners*" on page 40)
19. Refit the drive belts and correctly adjust their tension. (Refer to Section 6.9 "*Adjust Rotor Drive Belt Tension*" on page 43.)

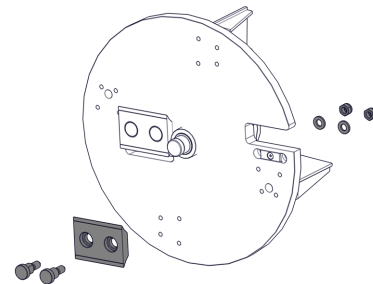

Figure 22 - Blade Mounting



6.9 Adjust Rotor Drive Belt Tension

There will normally be a rapid drop in tension during the run-in period for new belts. When new belts are fitted, check the tension every 2 - 3 hours and adjust until the tension remains constant.

Too much tension shortens belt and bearing life.

Too little tension will cause poor performance, especially in respect of no-stress devices.

Belt failures due to lack of correct tensioning will not be covered under your Timberwolf warranty.

1. Remove the engine bay side panel.
2. Use a 19 mm spanner to loosen the bolt in the centre of the tensioner pulley until the pulley is able to slide with minimal wobble (Figure 23, Item 1).
3. Turn the nut on the end of the tensioner pulley slider until the correct belt tension is achieved (Figure 23, Item 2). (Refer to Section 6.10 "V- Belt Tensioning Procedure" on page 44.)
4. Tighten the bolt in the centre of the tensioner pulley.
5. Run the machine then re-check the belt tension.

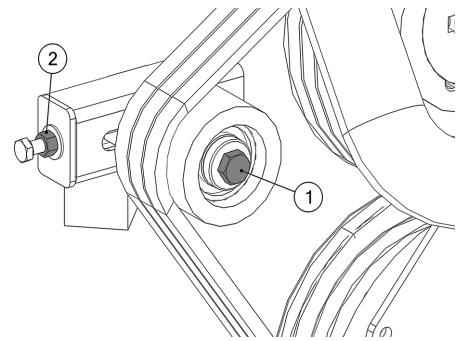

Figure 23 - Tensioner Pulley Assembly



6.10 V-Belt Tensioning Procedure

Set the deflection distance on the lower scale of the tension gauge so that the underside of the O-ring equals the 'h' value given in Figure 24.

Ensure that the deflection force scale is zeroed by pushing the upper O-ring all the way down.

Place the tension gauge in the centre of the belt span as shown in Figure 24.

Press downwards on the rubber buffer, deflecting the belt until the underside of the lower O-ring is level with the belt behind. (If there is only one belt, use a straight edge.)

Take the reading from the deflection scale of the tension meter (read at the lower edge of the O-ring) and compare with the value given in Table 7.

Adjust the belt tension as required, to achieve the correct tension. (Refer to Section 6.9 "Adjust Rotor Drive Belt Tension" on page 43.)

Table 6 - Rotor Drive Belt Pulleys

1	Belt tensioner
2	Rotor pulley
3	Engine pulley

Table 7 - Rotor Drive Belt Specifications

TW 230HB		
Manufacturer	Gates	
Type	Quad Power IV	
Pitch Designation	XPA	
Length	1157 mm	
Deflection (h)	2.68 mm	
Force (Kg)	New Belt	2.64 - 2.82
	Used Belt	2.26 - 2.45

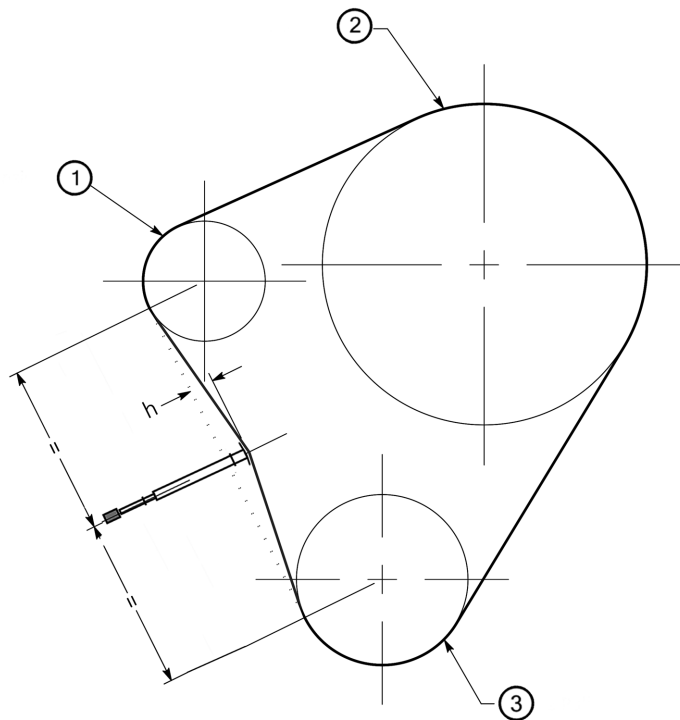

Figure 24 - Rotor Drive Belt Layout



6.11 Change Hydraulic Oil and Filter



Warning

Use plastic gloves to keep oil off skin. Dispose of used oil and filter in an ecologically sound way.

1. Ensure the chipper is in a safe condition. (Refer to Section 6.1 "Safe Maintenance" on page 35.)
2. Ensure the chipper is level.
3. Clear all debris from around the hydraulic tank (Figure 25).
4. Remove the black screw cap from the top of the filter housing.
5. Partially remove the filter element from the inner cup and leave for 15 minutes to drain.
6. Remove the filter element from the cup.
7. Remove the drain plug and drain the oil into a suitable container.
8. Replace the drain plug.
9. Refill with hydraulic oil VG32 to between the 'Min' and 'Max' lines on the tank (15 litres) (Figure 25).
10. Refit the filter cup, with a new filter element, and refit the black screw cap. (Ensure the O-ring seal stays in place.)

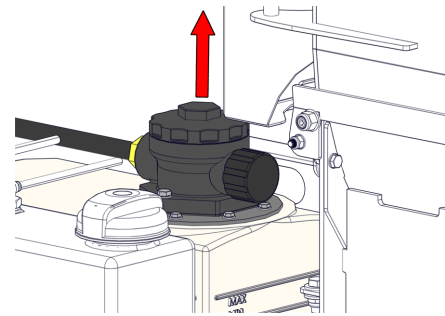

Figure 25 - Hydraulic Tank

N.B. Use of the incorrect grade of hydraulic oil will cause running issues and block the filters.

6.12 Check Hoses

The hydraulic roller system operates at extremely high pressures and must be maintained in a safe working condition. All the hydraulic hoses should be regularly inspected for any signs of damage, chafing or leaks.

The hoses that run to the top motor have the highest chance of damage as they are constantly moving.

If any hydraulic components are changed, new seals should be used on re-assembly and all fittings should be re-tightened.



6.13 Grease the Discharge Tube Mounting Flanges

1. Ensure the chipper is in a safe condition. (Refer to Section 6.1 "Safe Maintenance" on page 35.)
2. Remove the discharge tube.
3. Remove all traces of old grease and dirt from the discharge tube flange and the mounting flange (Figure 26).
4. Apply multi-purpose grease to both flanges.
5. Refit the discharge tube.

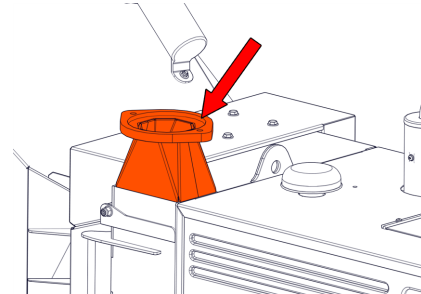

Figure 26 - Discharge flange - tube removed

6.14 Grease the Roller Box Slides

Carry out regularly. In dirty or dusty conditions, or during periods of hard work, at least weekly. If the slides become dry the top roller may hang up and the pulling-in power of the rollers will be reduced. This may lead to excessive wear.



DO NOT USE GRAPHITE BASED GREASE.

1. Ensure the chipper is in a safe condition. (Refer to Section 6.1 "Safe Maintenance" on page 35.)
2. Unbolt and remove the roller box guard (Figure 27).
3. Remove the rotor housing blade access hatch. (Refer to Section 6.8 "Change Blades" on page 41.)
4. Remove all traces of old grease and dirt.
5. Apply thin grease, with a brush, directly to the slide surfaces, including the inner cheeks of the slider (Figure 28).
6. Refit and secure the rotor housing blade access hatch and the roller box guard.

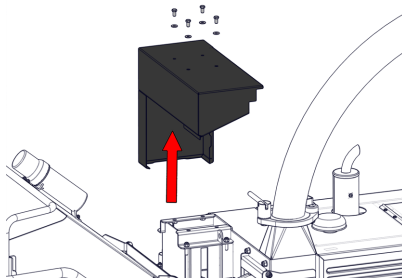

Figure 27 - Removing the Roller Box Guard

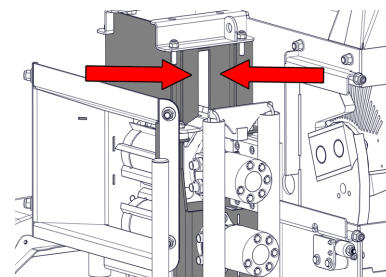

Figure 28 - Greasing the Roller box Slides



6.15 Grease the Roller Splines and Rotor Bearings

Carry out regularly. In dirty or dusty conditions, or during periods of hard work, at least daily. If the bearings and splines are allowed to run dry, premature wear will occur, resulting in a breakdown and the need for replacement parts. A failure caused by lack of greasing is not covered by warranty. Early signs of insufficient grease include squeaking, or knocking rollers.



Caution

DO NOT USE GRAPHITE BASED GREASE.

It is recommended to grease all the nipples whilst the engine is running and the rollers are turning. This will ensure the grease is evenly distributed.

1. Locate the greasing panel (Figure 29).
2. Apply 4+ pumps of grease to each nipple.
3. The front and rear bearings are greased by nipples 'a' and 'b'.
4. The top and bottom roller splines are greased by nipples 'c' and 'd'.

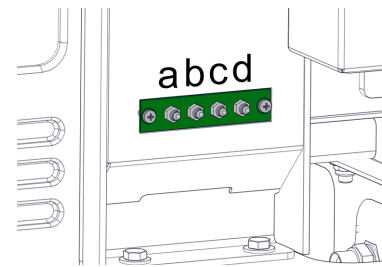

Figure 29 - Greasing Panel



THIS PAGE INTENTIONALLY LEFT BLANK



7

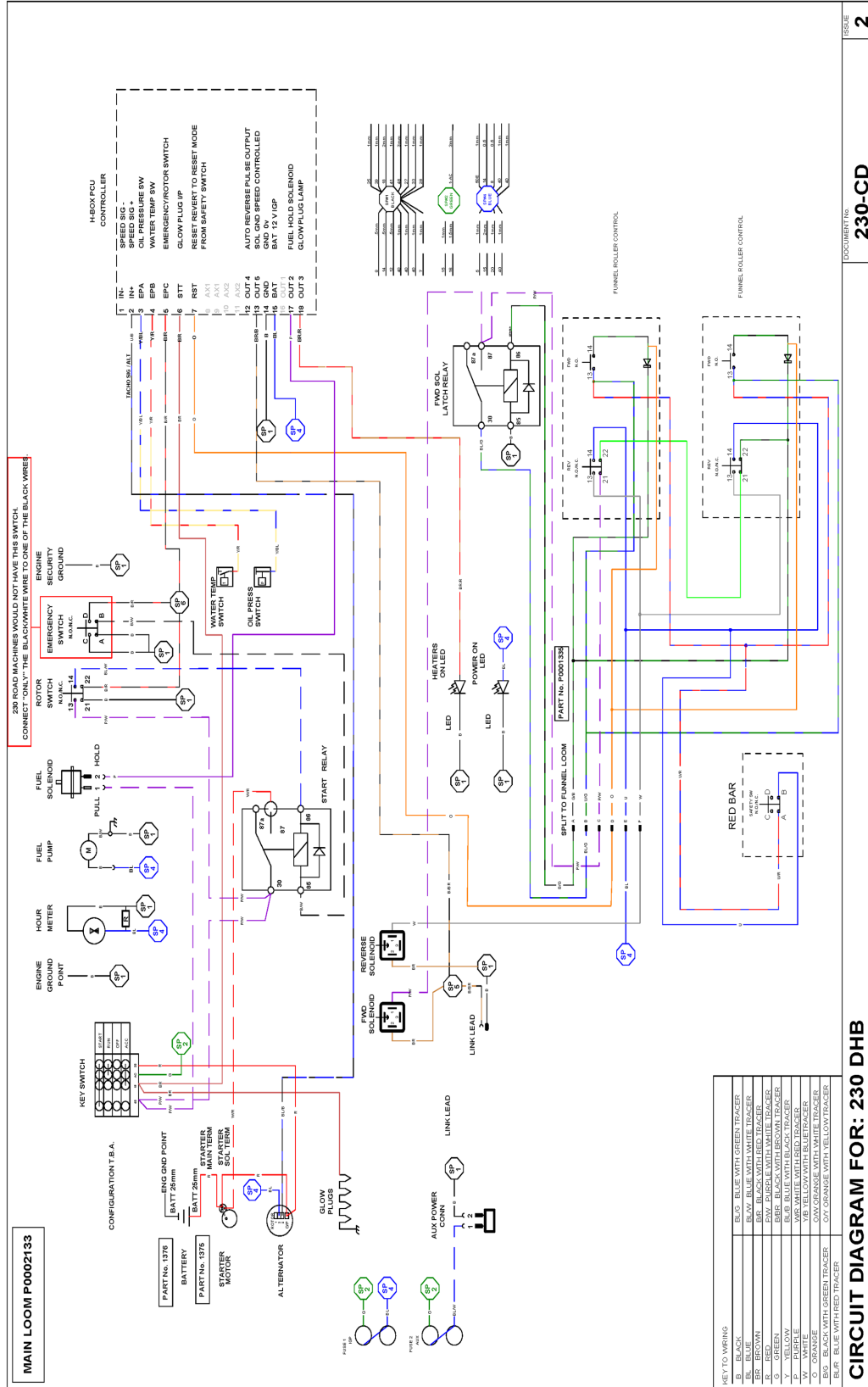



THIS PAGE INTENTIONALLY LEFT BLANK



8

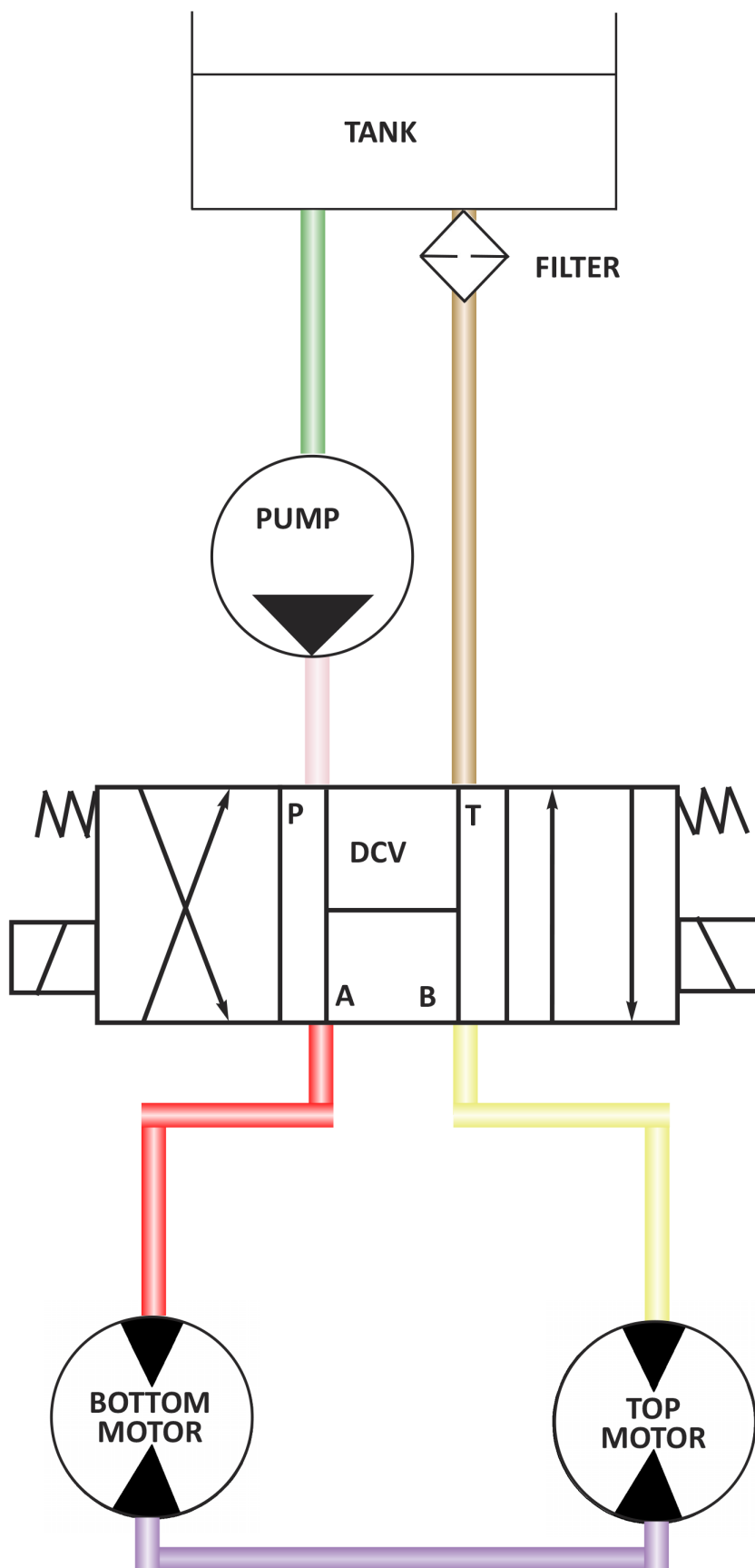



THIS PAGE INTENTIONALLY LEFT BLANK



9 Storage

9.1 Preparing for Storage

1. Allow the engine to cool down completely.
2. Clean the chipper, removing all wood chips.
3. Apply fresh grease (Section 6.13 "*Grease the Discharge Tube Mounting Flanges*" on page 46, Section 6.14 "*Grease the Roller Box Slides*" on page 46, and Section 6.15 "*Grease the Roller Splines and Rotor Bearings*" on page 47.)
4. Check all fasteners and tighten as required. (Section 6.7 "*Check and Replace Fasteners*" on page 40.)
5. Remove all fuel from the tank. Refit fuel tank drain plug. (Section 6.7 "*Check and Replace Fasteners*" on page 40.)
6. Disconnect the battery negative cable, if the battery is being left in the machine. (Section 6.6 "*Battery Safety Information*" on page 38.)
7. Touch up damaged paint, or protect with a suitable lubricant.

9.2 Storage Conditions



Regardless of storage time, the chipper must always be stored in a stable position. (Refer to Section 4.4 "*Stabilising the Chipper*" on page 23.)

1. Store the chipper in a dry place between +5°C and +40°C. Timberwolf strongly recommend the machine is stored in a sheltered location, protected from rain. If stored outside, protect with a tarpaulin.
2. If the relative humidity of the storage environment is >60%, the engine shaft must be rotated by hand, 1-2 revolutions, bi-weekly. Before rotating the shaft, apply 20-30 ml of engine oil to the bearing liner.
3. All breathers and drains are to be operable, or the drain plugs removed. The chipper must be stored so the drain(s) are at the lowest point.

9.3 3-Monthly Storage Checks

1. Recheck and touch up damaged paint, or protect with a suitable lubricant.
2. Operate the handbrake mechanism to ensure it functions correctly.
3. Check and restore tyre pressures.

9.4 6-Monthly Storage Checks

1. Refer to Section 9.3 "*3-Monthly Storage Checks*" on page 53, and complete all the checks.
2. Clean and drain all lubrication lines, including grease pipes, fuel lines, coolant and oil reservoirs. Replace with new lubricants.



9.5 12-Monthly Storage Checks

1. Refer to Section 9.4 "6-Monthly Storage Checks" on page 53, and complete all the checks.
2. Inspect the bearing lubrication system for the presence of water. If water is detected, flush out the bearing housing and re-lubricate immediately.

9.6 Recommissioning after Storage

1. Ensure the chipper is stable. (Section 4.4 "Stabilising the Chipper" on page 23.)
2. Remove all guards and check all fasteners. (Section 6.7 "Check and Replace Fasteners" on page 40.)
3. Ensure the discharge tube is greased (Section 6.13 "Grease the Discharge Tube Mounting Flanges" on page 46), fastened, free of blockages, rotates through its full range of movement and cannot face the operators working position.
4. Ensure the feed funnel is free from foreign objects (e.g. tools or clothing).
5. Open and close the feed tray to ensure it operates correctly.
6. Check fuel, engine oil and hydraulic fluid levels and top up as required. *
7. Inspect all internal parts (e.g. drive belts, taper locks and shaft key-ways).
8. Check belt tension. (Section 6.9 "Adjust Rotor Drive Belt Tension" on page 43.)
9. Inspect the cutting blades to ensure they are sharp and suitable for use.
10. Refit all guards.



Before reconnecting the battery cables ensure that the machine is in a well-ventilated area and that any fuel fumes have been allowed to dissipate.

11. Connect the battery cables. (Section 6.6 "Battery Safety Information" on page 38.)
12. Carry out an electrical diagnostic continuity check, to ensure the circuit is complete.
13. Check and restore the tyre pressures.
14. Lubricate all grease pipes. Remove pipes and bleed the system prior to use, if necessary. *
15. Carry out normal daily checks before starting. (Section 5.6 "Checks Before Starting" on page 28.)
16. Start the engine.
17. Run for 15 minutes at half throttle, to clear the engine.
18. Run for a further 5 minutes at full throttle, prior to any cutting activity.

Notice * Storage fluids and greases should be replaced. DO NOT use old fluids or greases.



10 Dismantling and Disposal

Follow these guidelines, using approved local waste and disposal agencies for recycled materials, according to applicable Health, Safety and Environmental laws.

- Position the machine within reach of all necessary lifting equipment.
- Use correct PPE. (Refer to Section 3.2 "*Operator's Personal Protective Equipment (PPE)*" on page 17.)
- Remove all hazardous materials and battery and store safely before disposal. (Refer to Section 1.4 "*Hazardous Materials*" on page 6, and Section 6.6 "*Battery Safety Information*" on page 38.)
- Dismantle the machine. (Refer to Section 6 "*Maintenance Instructions*" on page 35.) Pay attention to parts with mechanical pressure or tension applied, including springs.
- Separate items that continue to have a service life.
- Separate worn items into material groups and, where possible, recycle using available agencies for recycled materials (Table 8).

Table 8 - Material Types

Steel	Plastics
Non-ferrous metals	Rubber
Aluminium	Electrical and electronic components
Brass	Other materials that CAN be recycled
Copper	Other materials that CANNOT be recycled

- If a part is not easily separated into different material groups, it should be treated as material that cannot be recycled.
- Do not burn discarded materials.
- Change the machinery records to show that the machine is out of service and discarded. Supply the machine serial number to Timberwolf to close their records.



THIS PAGE INTENTIONALLY LEFT BLANK



11 Declaration of Conformity

Timberwolf Ltd
Entec House, Tomo Industrial Estate, Stowmarket IP14 5AY
Telephone: 01449 765800
Email: sales@timberwolf-uk.com Web site: timberwolf-uk.com



TIMBERWOLF
Lead the pack

EC Declaration of Conformity



We
Timberwolf Ltd.
Of
Entec House,
Tomo Industrial Estate,
Stowmarket,
IP14 5AY
United Kingdom
Tel: 0044 (0) 1449 765800
Email: sales@timberwolf-uk.com

Hereby declare that this Declaration of Conformity is issued under our sole responsibility and that the following objects of the declaration:

Product Range: Timberwolf TW 230, Road Tow and Tracked 6" Woodchippers
Model(s): TW 230H, TW 230VTR,
Type(s): TW 230HB (Diesel), TW 230HB (Petrol), TW 230H(a) (Diesel), TW 230H(a) (Petrol)
TW 230VTR (Diesel), TW 230VTR (Petrol)
Serial No(s): TW 230HB (Diesel): 24A0LS240001, onwards
TW 230HB (Petrol): 37A0LS241001, onwards
TW 230H(a) (Diesel): 24A0LS243001, onwards
TW 230H(a) (Petrol): 37A0LS245001, onwards
TW 230VTR (Diesel): 24A0LS237001, onwards
TW 230VTR (Petrol): 37A0LS242001, onwards

Comply with all applicable essential health and safety requirements-and are in conformity with the following EU Directives and Union harmonised legislation:

2006/42/EC	Machinery Directive
2014/30/EU	Electromagnetic Compatibility Directive
2000/14/EC	Noise Emission in the Environment by Equipment for Use Outdoors (Guaranteed Sound Power: 118dB(A); Measured Sound Power Level: 96dB(A))

The following harmonised standards, including part/clauses of, have been applied:

Machinery Directive: BS EN 13525:2020: Forestry machinery —Wood chippers —Safety, BS EN ISO 12100:2010: Safety of Machinery — General principles for design — Risk assessment and risk reduction.

EMC Directive: BS EN ISO 14982:2009: Agricultural and forestry machinery – Electromagnetic Compatibility – Test methods and acceptance criteria.

Noise Directive: BS EN ISO 3744:2010: Acoustics - Determination of sound power levels and sound energy levels of noise sources using sound pressure - Engineering methods for an essentially free field over a reflecting plane.

Signed at Entec House, Stowmarket for and on behalf of Timberwolf Ltd by:

Mr Chris Perry (Managing Director):

Dated: 14th June 2021

Timberwolf Ltd registered in England under No. 03477258. Registered office as above.



THIS PAGE INTENTIONALLY LEFT BLANK



12 Notes



TIMBERWOLF®

Lead the Pack